

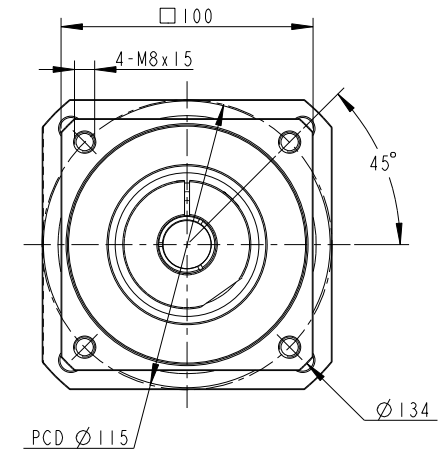

PA II 115 - 040 - S2 / OMRON R88M-K1K030(F/C)

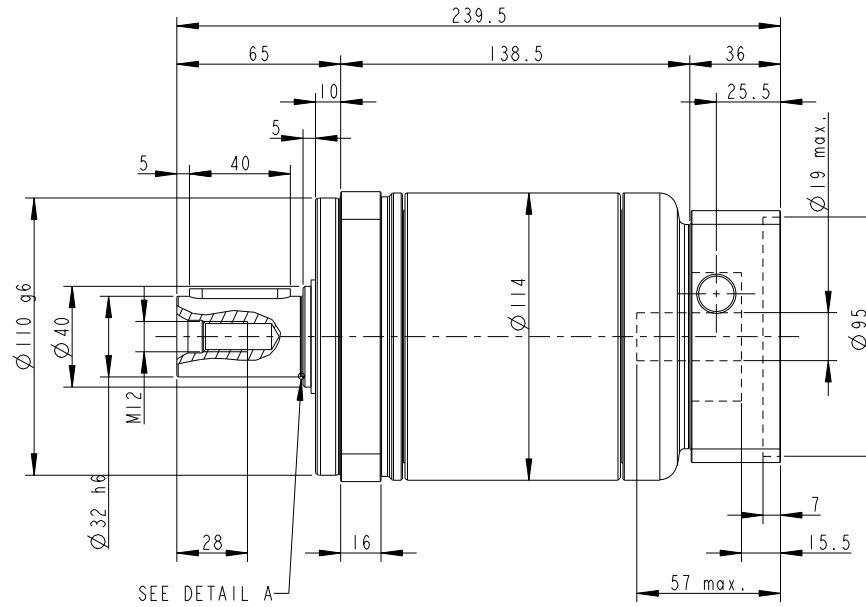

INERTIA: 1.83 ~ 2.41 kg-cm²
 MASS: 8.4 Kg

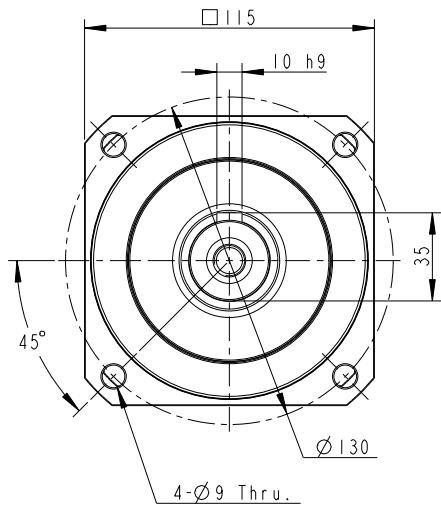
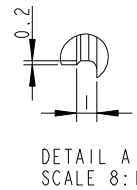

DETAIL A
 SCALE 8:1

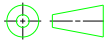
PART NO. PA2-115_2ST_19-P0411401701 AD-PE2-S19-M100-1		 APEX DYNAMICS, INC.	
APPROVALS	DATE	TITLE PA2-115_2 Stages_S19 , RATIO= 12~100 AND MOTOR FLANGE MOUNTING	
DRAWN 沈正義		DWG NO. PA2-115_2ST_19-P0411401701	
CHECKED			SIZE A1
APPROVED			SCALE 1:1
			REV