

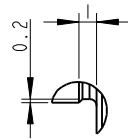

PG II 080 - 010 / KINCO SMS80S-0075-30xxK-3LKU

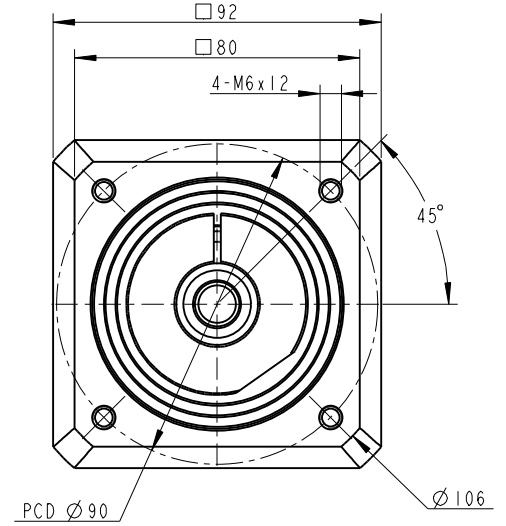
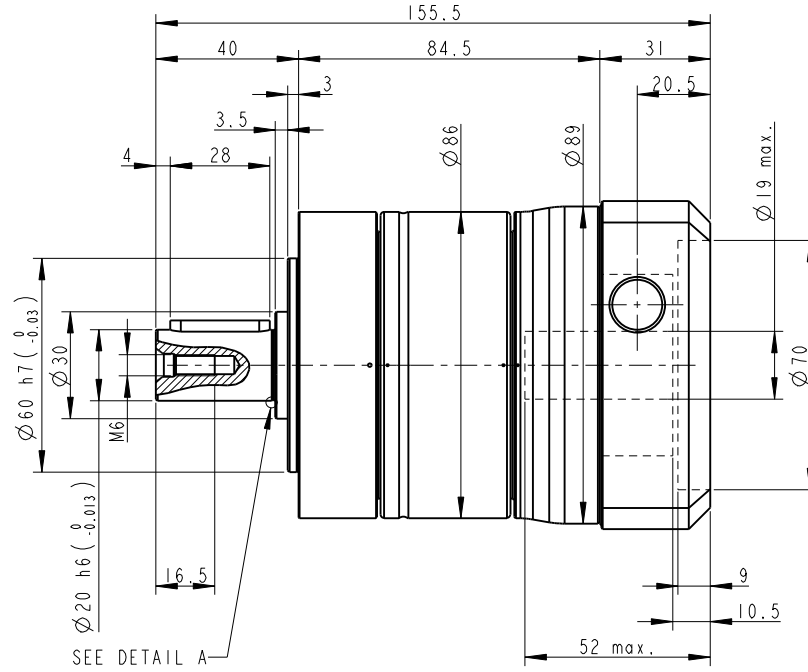
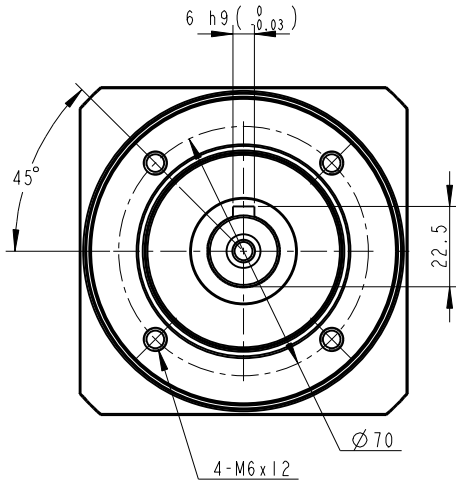

DETAIL A
 SCALE 5:1

INERTIA: 1.63 ~ 1.77 kg-cm²
 MASS: 3 Kg

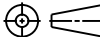
PART NO. PG2-080_IST_19-P0411400503 AD-PE2-S19-M80-3		 APEX DYNAMICS, INC.		
APPROVALS	DATE	TITLE PG2-080_1 Stage_S19 , RATIO= 3-10 AND MOTOR FLANGE MOUNTING		
DRAWN 高俊志		DWG NO. PG2-080_IST_19-P0411400503		
CHECKED			SIZE A2	SCALE 1:1
APPROVED			REV	