

User's Manual For M542

Low Cost Microstepping Driver

Version 1.0

©2000 All Rights Reserved

Attention: Please read this manual carefully before using driver!



The content in this manual has been carefully prepared and is believed to be accurate, but no responsibility is assumed for inaccuracies.

Leadshine reserves the right to make changes without further notice to any products herein to improve reliability, function or design. Leadshine does not assume any liability arising out of the application or use of any product or circuit described herein; neither does it convey any license under its patent rights of others.

Leadshine's general policy does not recommend the use of its products in life support or aircraft applications wherein a failure or malfunction of the product may directly threaten life or injury. According to Leadshine's terms and conditions of sales, the user of Leadshine's products in life support or aircraft applications assumes all risks of such use and indemnifies Leadshine against all damages.

©2000 by Leadshine Technology Company Limited.
All Rights Reserved



Leadshine Technology Co., Ltd.

Floor 6, Block B, Yuehai Building, Nanhai Avenue, Shenzhen, China

PH. (86)755-26471129, FAX (86)755-26402718

Internet: www.leadshine.com E-Mail: sales@leadshine.com

Table of Contents

1. Introduction, Features and Applications	2
2. Specifications and Operating Environment	3
3. Driver Connectors P1 and P2	4
4. Control Signal Connector (P1) Interface	5
5. Driver Connection to Motors (P2)	6
6. Power Supply and Driver Voltage and Current	9
7. Selecting Microstep Resolution and Driver Current Output	11
8. Protection Functions	12
9. Connection Diagram for Driver, Motor, Controller	13
10. Control Signal Waveform and Timing	13
11. Wire Connection	14
12. FAQ	14
Appendix: Limited Warranty	16

1. Introduction, Features and Applications

M542 is a low cost high performance microstepping driver based on most advanced technology in the world today. It is suitable for driving any 2-phase and 4-phase hybrid step motors. By using advanced bipolar constant-current chopping technique, it can output more speed and power from the same motor, compared with traditional technologies such as L/R drivers. Its 3-state current control technology allows coil currents to be well controlled, with relatively small current ripple and therefore less motor heating.

Features of this driver

- Patented technology
- High performance, low cost
- Supply voltage up to +50VDC, current output up to 4.2A peak
- Optically isolated input signals, pulse frequency up to 400 KHz
- Automatic idle-current reduction
- 3-state current control for less motor heating
- 16 selectable resolutions in decimal and binary
- Suitable for 4,6,8 lead motors
- Stepping on upward or downward pulse edge (selectable)
- DIP switch current setting with 8 different value
- CW/CCW mode available (optional)
- Over-voltage and short-circuit protection
- Small size (118x75.5x33mm)

Applications of this driver

Suitable for a wide range of stepping motors of Nema 17, 23 and 34, and usable for various kinds of machines, such as X-Y tables, labeling machines, laser cutters, engraving machines, and pick-place devices. Particularly useful in applications with low vibration, high speed and high precision are desired.

2. Specifications and Operating Environment

Electric Specifications ($T_j = 25^\circ\text{C}$)

Parameters	M542			Unit
	Min.	Typical	Max.	
Output Current	0.54	-	4.2(RMS 3A)	Amps
Supply voltage (DC)	20	36	50	VDC
Logic signal current	7	10	16	mA
Pulse input frequency	0	-	300	Khz
Isolation resistance	500			MΩ

Operating Environment and Parameters

Cooling	Natural cooling or forced convection	
Environment	Space	Avoid dust, oil frost and corrosive gas
	Temperature	0° - 50
	Humidity	40 - 90%RH
	Vibration	5.9m/s ² Max
Storage Temp.	-20 - 125	
Weight	Approx. 0.280 Kg (9.9 oz)	

Mechanical Dimensions (unit:mm, 1 inch = 25.4 mm)

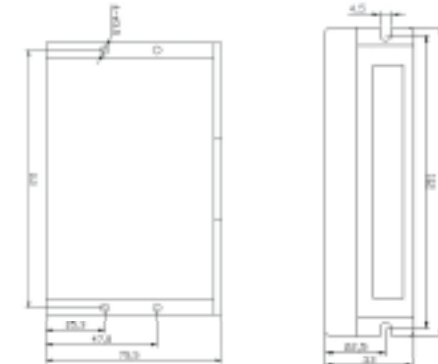

Front View

Side View

Figure 1: Mechanical dimensions

*Recommended to use side mounting for better heat dissipation

Extra Heat Sink

- Driver's reliable working temperature should be <65 °C, motor temperature <80 °C ;
- It is recommended automatic half-current mode, i.e. current automatically reduced by 60% when motor stops, so as to decrease driver and motor's heating;
- Please mount the driver vertically to maximize heat sink area.

3. Driver Connectors, P1 and P2

The driver has two connectors, P1 for control signals, and P2 for power and motor connections.

The following is a brief description of the two connectors of the driver. More detailed descriptions of the pins and related issues are presented in section 4, 5, 6, 9.

Control Signal Connector P1-pins

Signal	Functions
PUL+ (+5V)	Pulse signal: in single pulse(pulse/direction) mode, this input represents pulse signal, effective for each upward – rising edge; in double pulse mode (pulse/pulse) this input represents clockwise(CW)pulse. For reliable response, pulse width should be longer than 1.5μs.
PUL- (PUL)	
DIR+ (+5V)	Direction signal: in single-pulse mode, this signal has low/high voltage levels, representing two directions of motor rotation; in double-pulse mode (set by inside jumper JMP1), this signal is counter-clock (CCW) pulse, effective on each rising edge. For reliable motion response, direction signal should be sent to driver 2μs before the first pulse in the reverse motion direction.
DIR- (DIR)	
ENA+ (+5V)	Enable signal: this signal is used for enable/disable, high level for enabling driver and low level for disabling driver. Usually left unconnected(enabled).
ENA- (ENA)	

Remark 1: Pul/dir is the default mode, under-cover jumper JMP1 can be used to switch to CW/CCW double-pulse mode.

Remark 2: Please note motion direction is also related to motor-driver wiring match. Exchanging the connection of two wires for a coil to the driver will reverse motion direction. (for example, reconnecting motor A+ to driver A- and motor A- to driver A+ will invert motion direction).

Power connector P2 pins

Pin No.	Signal	Functions
1	Gnd	DC power ground
2	+V	DC power supply, +20VDC - +50VDC, Including voltage fluctuation and EMF voltage.
3, 4	Phase A	Motor coil A (leads A+ and A-)
5, 6	Phase B	Motor coil B (leads B+ and B-)

4. Control Signal Connector (P1) Interface

This driver uses differential inputs to increase noise immunity and interface flexibility. Single-ended control signals from the indexer/controller can also be accepted by this interface. The input circuit has built-in high-speed opto -coupler, and can accept signals in the format of line driver, open-collector, or PNP output. Line driver (differential) signals are suggested for reliability.

In the following figures, connections to open-collector and PNP signals are illustrated.

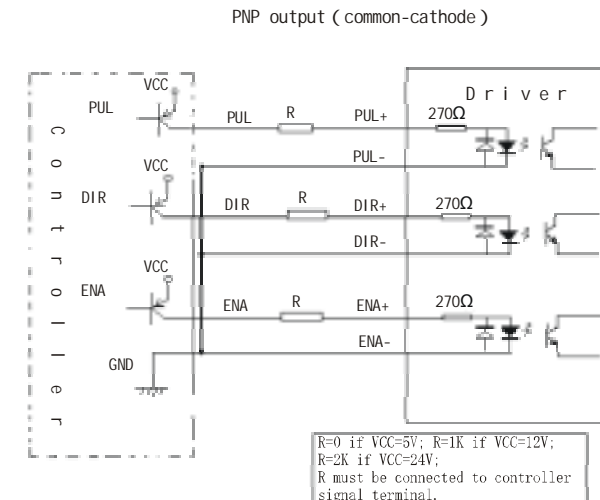
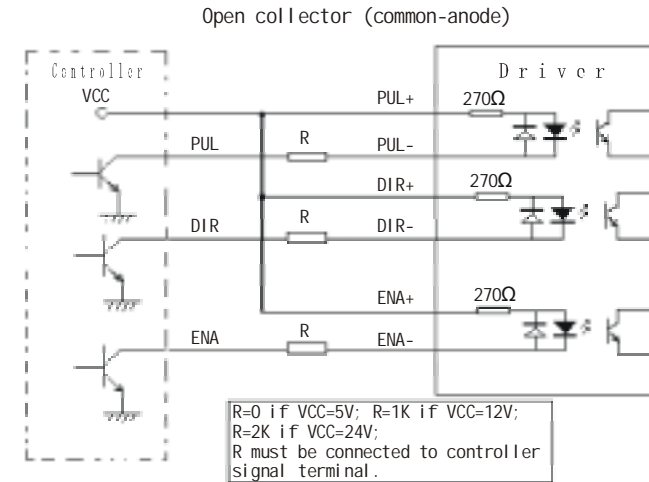

Selecting Effective Pulse Edge

M542 can move motor one microstep upon receiving the upward-rising or downward-falling edge of a pulse, depending on the JMP1 setting under driver cover, as shown on the below, default setting is upward-rising edge effective.

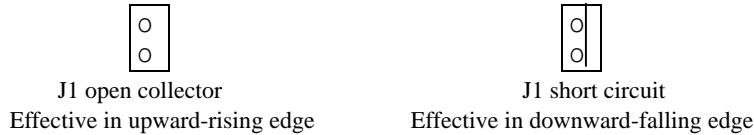

Selecting CW/CCW and PUL/DIR Mode

There is a jumper JMP3 inside the driver specifically for the purpose of selecting pulse signal mode. Settings for one-pulse mode (PUL/DIR) and for double-pulse mode (CW/CCW) are shown on the following. Default mode out of factory is PUL/DIR mode.



5. Driver Connection to Step Motors

M542 driver can drive any 4, 6, 8 lead hybrid step motors. The following diagrams illustrate connection to various kinds of motor leads:

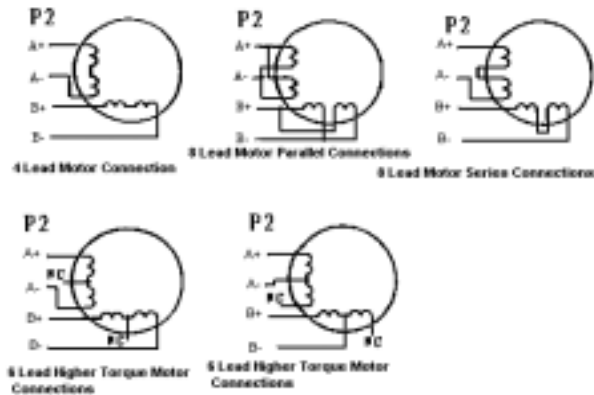

Figure 3: Driver Connection to Step Motor

Note that when two coils are parallelly connected, coil inductance is reduced by half and motor speed can be significantly increased. Serial connection will lead to increased inductance and thus the motor can be run well only at lower speeds.

5.1 Connecting to 8-Lead Motors

8 lead motors offer a high degree of flexibility to the system designer in that they may be connected in series or parallel, thus satisfying a wide range of applications.

Series Connection

A series motor configuration would typically be used in applications where a higher torque at lower speeds is required. Because this configuration has the most inductance, the performance will start to degrade at higher speeds. Use the per phase (or unipolar) current rating as the peak output current, or multiply the bipolar current rating by 1.4 to determine the peak output current.

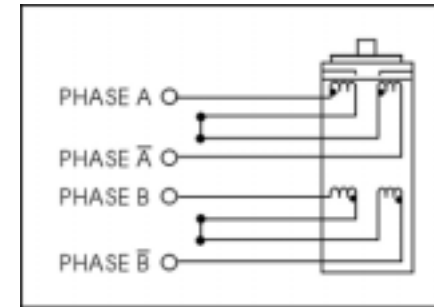

Figure 4: 8 Lead Motor Series Connections

Parallel Connection

An 8 lead motor in a parallel configuration offers a more stable, but lower torque at lower speeds. But because of the lower inductance, there will be higher torque at higher speeds. Multiply the per phase (or unipolar) current rating by 1.96, or the bipolar current rating by 1.4, to determine the peak output current.

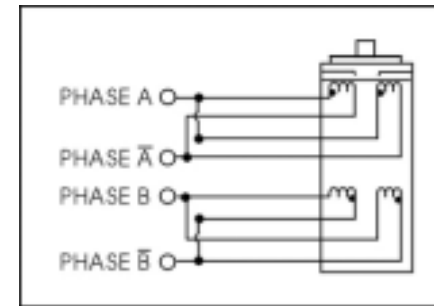

Figure 5: 8 Lead Motor Parallel Connections

5.2 Connection to 6-Lead Motors

Like 8 lead stepping motors, 6 lead motors have two configurations available for high speed or high torque operation. The higher speed configuration, or half coil, is so described because it uses

one half of the motor's inductor windings. The higher torque configuration, or full coil, use the full windings of the phases.

Half Coil Configuration

As previously stated, the half coil configuration uses 50% of the motor phase windings. This gives lower inductance, hence, lower torque output. Like the parallel connection of 8 lead motor, the torque output will be more stable at higher speeds. This configuration is also referred to as bal copper. In setting the driver output current multiply the specified per phase (or unipolar) current rating by 1.4 to determine the peak output current.

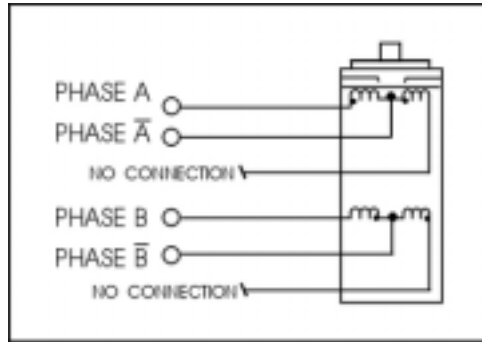

Figure 6: 6 Lead Half Coil (Higher Speed) Motor Connections

Full Coil Configuration

The full coil configuration on a six lead motor should be used in applications where higher torque at lower speeds is desired. This configuration is also referred to as full copper. Use the per phase (or unipolar) current rating as the peak output current.

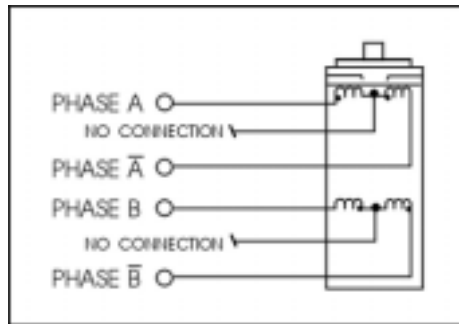

Figure 7: 6 Lead Full Coil (Higher Torque) Motor

5.3 Connection to 4-Lead Motors

4 lead motors are the least flexible but easiest to wire. Speed and torque will depend on winding inductance. In setting the driver output current, multiply the specified phase current by 1.4 to determine the peak output current.

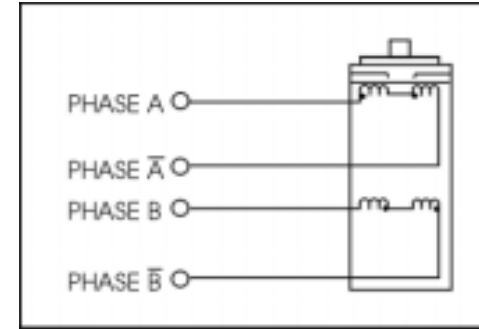

Figure 8: 4 Lead Motor Connections

6. Power supply Selection, Driver Voltage and Current Selection

6.1 Power Supply Selection

It is important to choose appropriate power supply to make the driver operate properly and deliver optimal performance.

Maximum Voltage Input:

The power MOSFETS inside the driver can actually operate within +20V - +50VDC, including power input fluctuation and back EMF voltage generated by motor coils during motor shaft deceleration. Higher voltage will damage the driver. Therefore, it is suggested to use power supplies with theoretical output voltage of no more than +52V, leaving room for power line fluctuation and Back EMF.

Regulated or Unregulated power supply:

Both regulated and unregulated power supplies can be used to supply DC power to the driver. However, unregulated power supplies are preferred due to their ability to withstand current surge. If regulated power supply (such as most switching supplies.) is indeed used, it is important to have large current output rating to avoid problems like current clamp, for example using 4A supply for 3A motor-driver operation. On the other hand, if unregulated supply is used, one may use a power supply of lower current rating than that of motor (typically 50% ~ 70% of motor current). The reason is that the driver draws current from the power supply capacitor of the unregulated supply only during the ON duration of the PWM cycle, but not

during OFF duration. Therefore, the average current withdrawn from power supply is considerably less than motor current. For example, two 3A motors can be well supplied by one power supply of 4A rating.

Multiple drivers:

It is recommended to have multiple drivers to share one power supply to reduce cost, provided that the supply has enough capacity. To avoid cross interference, **DO NOT** daisy-chain the power supply input pin of the drivers. (instead, please connect them to power supply separately.)

Higher supply voltage will allow higher motor speed to be achieved, at the price of more noise and heating. If the motion speed requirement is low, it's better to use lower supply voltage to improve noise, heating and reliability.

NEVER connect power and ground in the wrong direction, as it will damage the driver.

6.2 Driver Voltage and Current Selection

This driver can match small and medium size step motors (NEMA 17, 23 & 34) made by Leadshine or other motor manufactures from around the world. To achieve good driving results, it is important to select supply voltage and output current properly. Generally, supply voltage determines the high speed performance of the motor, while output current determines the output torque of the driven motor (particularly at lower speed).

Selecting Supply Voltage:

Higher supply voltage can increase motor torque at higher speeds, thus helpful for avoiding losing steps. However, higher voltage may cause more motor vibration at lower speed, and it may also cause over-voltage protection and even driver damage. Therefore, it is suggested to choose only sufficiently high supply voltage for intended applications.

Setting Proper Output Current

- For a given motor, higher driver current will make the motor to output more torque, but at the same time causes more heating in the motor and driver. Therefore, output current is generally set to be such that the motor will not overheat for long time operation.
- Since parallel and serial connections of motor coils will significantly change resulting inductance and resistance, it is therefore important to set driver output current depending on motor phase current, motor leads and connection methods.
- Phase current rating supplied by motor manufacturer is important to selecting driver current, but the selection also depends on leads and connection.

7. Selecting Microstep Resolution and Driver Current Output

This driver uses an 8-bit DIP switch to set microstep resolution, and motor operating current, as shown below:

Current during motion Microstep resolution



7.1 Microstep Resolution Selection

Microstep resolution is set by SW5, 6, 7, 8 of the DIP switch as shown in the following table:

Microstep	ustep/rev.(for 1.8 ° motor)	SW5	SW6	SW7	SW8
2	400	Off	On	On	On
4	800	On	Off	On	On
8	1600	Off	Off	On	On
16	3200	On	On	Off	On
32	6400	Off	On	Off	On
64	12800	On	Off	Off	On
128	25600	Off	Off	Off	On
5	1000	On	On	On	Off
10	2000	Off	On	On	Off
20	4000	On	Off	On	Off
25	5000	Off	Off	On	Off
40	8000	On	On	Off	Off
50	10000	Off	On	Off	Off
100	20000	On	Off	Off	Off
125	25000	Off	Off	Off	Off

7.2 Current Setting

The first three bits (SW1, 2, 3) of the DIP switch are used to set the current during motion (dynamic current). Select a setting closest to your motor's required current.

● DIP Setting for current during motion:

Peak current	RMS	SW1	SW2	SW3
1.00A	0.71A	on	on	on
1.46A	1.04A	off	on	on

1.91A	1.36A	on	off	on
2.37A	1.69A	off	off	on
2.84A	2.03A	on	on	off
3.31A	2.36A	off	on	off
3.76A	2.69A	on	off	off
4.20A	3.00A	off	off	off

Remarks:

1) Due to motor inductance the actual current in the coil may be smaller than the dynamic current settings, particularly at higher speeds.

2) Static current setting

The current automatically reduced to 60% of dynamic current setting 1 second after the last pulse. This will, theoretically, reduce motor heating to 36% (due to I²I) of the original value. If the application needs a different idle current, please contact Leadshine for minor modification of circuit.

● **DIP setting for current during standstill:**

SW4 is used for this purpose, current setting due to coil inductance. OFF meaning that the standstill current is set to be half of the dynamic current, and ON meaning that standstill current is set to be the same as dynamic current.

8. Protection Functions

To improve reliability, the driver incorporates a number of built-in protections features.

a. Over-voltage protection

When power supply voltage exceeds +50VDC, protection will be activated and power indicator LED will turn red. When power supply voltage is lower than +20VDC, the driver will not work properly.

b. Coil-ground Short Circuit Protection

Protection will be activated in case of short circuit between motor coil and ground.

c. Over-current Protection

Protection will be activated in case of short current which may otherwise damage the driver.

Attention: since there is no protection against power leads (+, -) reversal, it is critical to make sure that power supply leads correctly connected to driver. Otherwise, the driver will be damaged instantly.

9. Connection Diagram for Driver, Motor, Controller

A complete stepping system should include stepping motor, stepping driver, power supply and controller (pulse generator).

A typical connection is shown below:

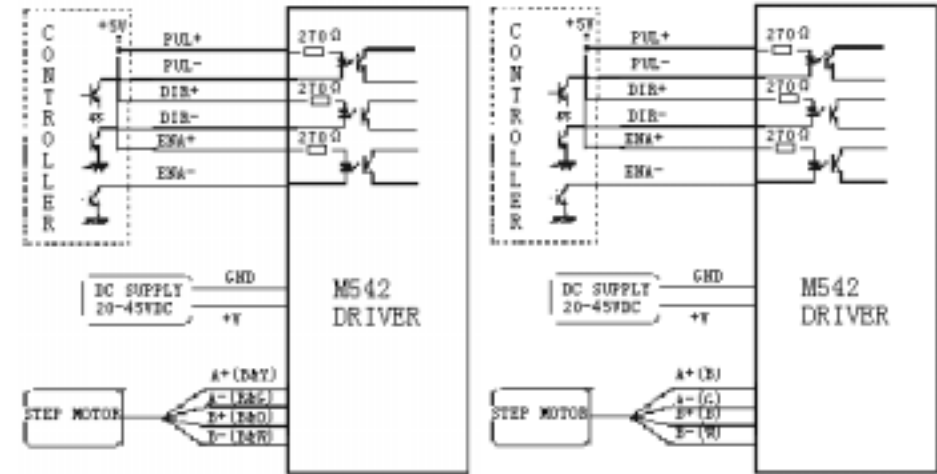
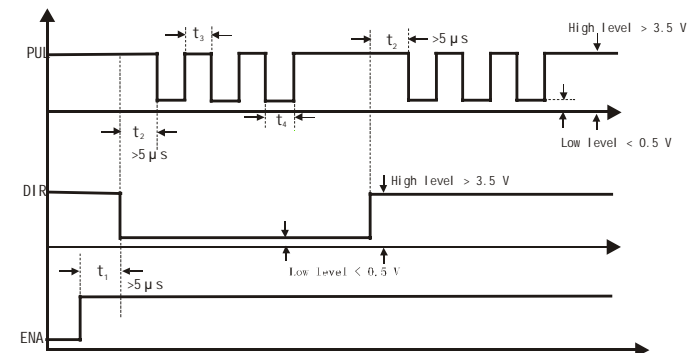

Figure 9: Driver connection in a stepping system

10. Control signal Waveform and Timing

In order to avoid some fault operation and deviation, PUL, DIR and ENA must accord with some parameters, as following diagram: (assuming JUMPER2 default setting is upward-rising edge of pulse being valid)



Remark:

- (1) t1: ENA must be ahead of DIR by at least 5us, logic HIGH as valid. Generally ENA+ and ENA- is NC (not connected).
- (2) t2: DIR must be ahead of PUL effective rising edge by 5us to ensure correct direction;
- (3) t3: Pulse width not less than 1.5us;
- (4) t4: low level width not less than 1.5us.

11. Wire Connection

- (1) In order to improve driver noise rejection, it is recommended to use twisted pair shield cable.
- (2) To prevent noise incurred in pulse/dir signal, Pulse/direction signal wires and motor wires should not be tied up together. It is better to separate them by at least 10 cm, otherwise the motor noise will easily disturb pulse direction signals, motor position error, system instability and other types of failure.
- (3) If a power supply serves several drivers, separate connections drivers is recommended instead of daisy-chaining.
- (4) It is prohibited to pull and plug connector P2 while driver is powered ON, as there is still high current flowing through coil even when motor is stopped. Pulling and plugging P2 with power on will cause extremely high voltage surge EMF, destroy the driver..

12. Frequent Asked Questions

In the event that your M542 doesn't operate properly, the first step is to identify whether the problem is electrical or mechanical in nature. The next step is to isolate the system component that is causing the problem. As part of this process you may have to disconnect the individual components that make up your system and verify that they operate independently. It is important to document each step in the troubleshooting process. You may need this documentation to refer back to at a later date, and these details will greatly assist our Technical Support staff in determining the problem should you need assistance.

Many of the problems that affect motion control systems can be traced to electrical noise, controller software errors, or mistake in wiring.

Problem Symptoms and Possible Causes

Symptom	Possible Problem
Motor not rotating	No power
	Invalid microstep resolution select setting
	DIP switch current setting is wrong
	Fault condition exists
Unit is disabled	Unit is disabled
	Motor phases may be connected in reverse
Motor rotating in the wrong direction	Motor phases may be connected in reverse
Unit in fault	DIP switch current setting is wrong
	Motor phase winding shorted
	Power input or output driver electrically overstressed
Erratic motor motion	Motor or power wiring unshielded or not twisted pair
	Logic wiring next to motor/power wiring
	Ground loop in system
	Open winding of motor
	Phase bad on driver
Motor stalls during acceleration	DIP switch current setting is wrong
	Motor is undersized for application
	Acceleration on controller is set too high
	Power supply voltage too low
Excessive motor and driver heating	Inadequate heat sinking / cooling
	Current reduction not being utilized
	Current set too high

In case of more questions, please contact our tech support at:

TEL: 86 755 26471129 FAX: 86 755 26402718 E-mail: tech@leadshine.com

TWELVE MONTH LIMITED WARRANTY

Leadshine Technology Co., Ltd. warrants its products against defects in materials and workmanship for a period of 12 months from receipt by the end-user. During the warranty period, Leadshine will either, at its option, repair or replace products which prove to be defective.

EXCLUSIONS

The above warranty shall not apply to defects resulting from: improper or inadequate handling by customer; improper or inadequate customer wiring; unauthorized modification or misuse; or operation outside of the electrical and/or environmental specifications for the product.

OBTAINING WARRANTY SERVICE

To obtain warranty service, a returned material authorization number (RMA) must be obtained from customer service at e-mail: tech@leadshine.com before returning product for service. Customer shall prepay shipping charges for products returned to Leadshine for warranty service, and Leadshine shall pay for return of products to customer.

WARRANTY LIMITATIONS

Leadshine makes no other warranty, either expressed or implied, with respect to the product. Leadshine specifically disclaims the implied warranties of merchantability and fitness for a particular purpose. Some jurisdictions do not allow limitations on how long and implied warranty lasts, so the above limitation or exclusion may not apply to you. However, any implied warranty of merchantability or fitness is limited to the 12-month duration of this written warranty.

Shipping Failed Product

If your product should fail during the warranty period, e-mail customer service at tech@leadshine.com to obtain a returned material authorization number (RMA) before returning product for service. Please include a written description of the problem along with contact name and address. Send failed product to distributor in your area or: Leadshine Technology Co., Ltd. Floor 6, Block B, Yuehai Building, Nanhai Avenue, Shenzhen, China. Also enclose information regarding the circumstances prior to product failure.